

NEMESIS PRO

WHEEL LOCK

1 YEAR
WARRANTY

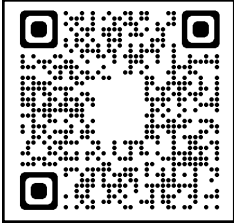

REGISTER NOW



PRODUCT CODE: FNPRO-100

INSTALLATION GUIDE

fullstop[®]
SECURITY

WWW.PURPLELINEUSA.COM | 925.215.7315
701 WILLOW PASS RD. STE 8, PITTSBURG, CA 94565

 purpleline[®]
design...innovate...improve

PARTS & FITTING DIAGRAMS

Your Saracen Pro comes with the below parts for installation:

1. Shield Plate
2. Wheel Bars
3. Lock Unit
4. Receiver Wheel Nuts (4)
5. Spacer Rings (x14)
6. Lock Unit Hex Screws
7. 3mm Hex Key
8. Key (x3)
9. Lock Cap
10. 19mm Wheel Wrench Adapter
11. Rim Shield

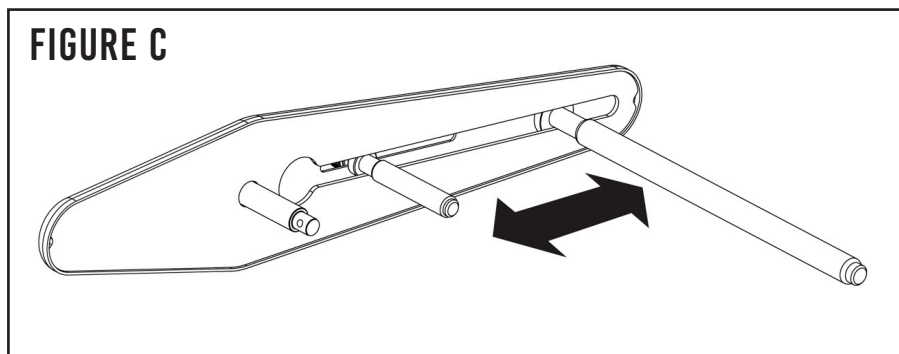
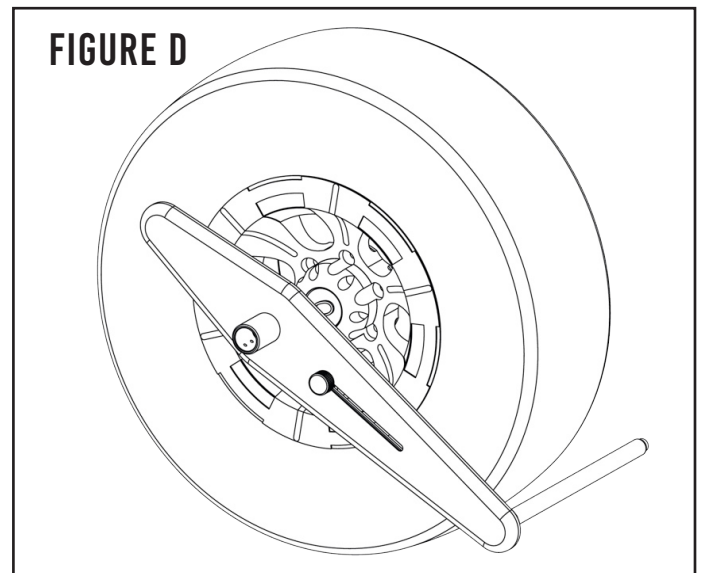
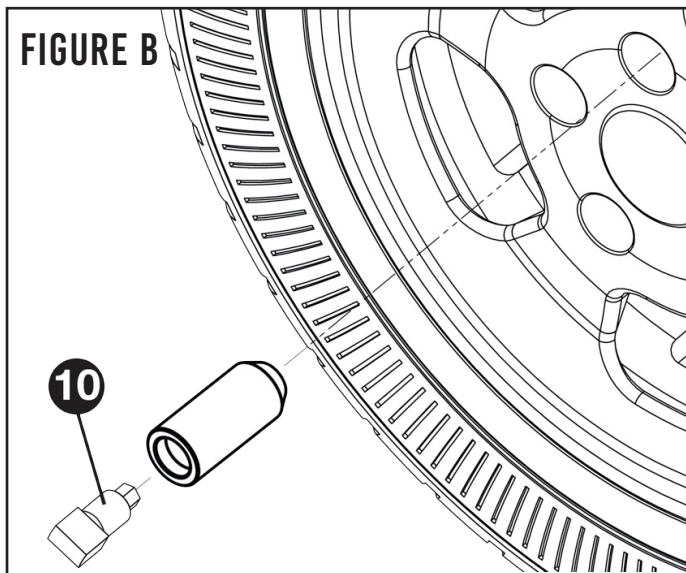
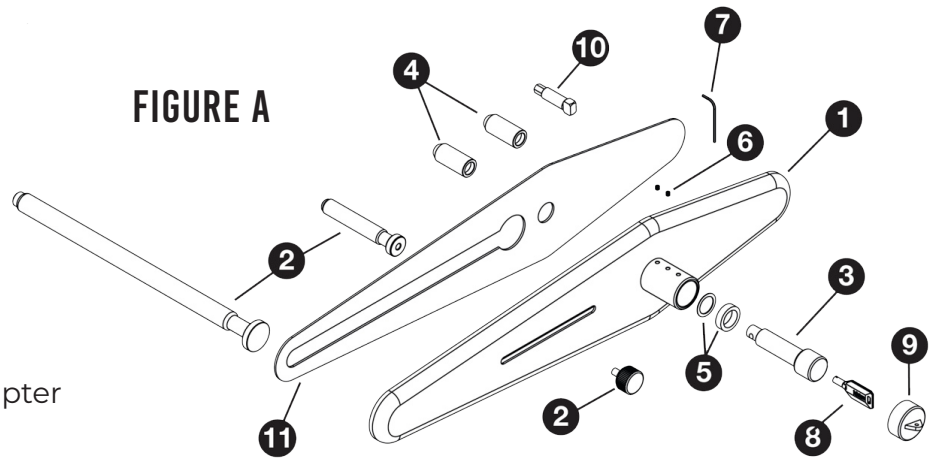

FULL INSTALLATION

The FullStop® Nemesis Pro Wheel Lock is designed to secure the shield onto a replacement wheel nut so that the Wheel Bars protrudes through one of the gaps in a wheel to prevent wheel rotation.

STEP 1

Before the product can be used, one of your existing wheel nuts must be removed and replaced with the Receiver Wheel Nut (4). This replacement nut has been designed to fit the majority of trailer road wheels, however, please check that your existing wheel nuts are of the same specification.

The supplied Receiver Nuts (4) are 1/2"-20 and 9/16"-18. If in any doubt consult the trailer manufacturer or wheel supplier BEFORE installation as it is possible to damage the hub of the trailer if the screw threads do not match.



Once you have removed one of the wheel nuts, the Receiver Wheel Nut (4) can be fitted using the Wheel Wrench Adapter (10) which enables you to use a standard 19mm wheel wrench (see Fig.B). The Receiver Wheel Nut (4) should be tightened to the correct torque setting for your wheels.

NOTE: Check your Owners Manual for details or consult a qualified technician. Do not over-tighten or use an impact wrench.

STEP 2

There are many possible combinations of how the Nemesis Pro may fit to a particular wheel. Fig.C shows that the Wheel Bars (2) are designed to slide in or out as necessary depending on where the Receiver Nut (4) has been installed in relation to which gap in the wheel's spokes.

NOTE: When installing the device the Wheel Bars (2) should be located through the spokes and outside of the wheel.



STEP 3

Before using the device it may be necessary to add Spacer Rings (5) to ensure that, when fitted, the back face of the Shield Plate (1) is as tight as possible to the face of the wheel when the Lock Unit (3) is locked into the Receiver Nut (4).

To check this, first fit one of the keys into the Lock Unit (3) and rotate it through 90° clockwise which releases the locking ball bearings. You can now install the Lock Unit (3) through the aperture in the Shield Plate (1) as shown in Fig. A.

Offer up the assembly to the Receiver Nut (4) and guide the end of the Lock Unit (3) into the Receiver Nut (4) as far as it will go. Lock them together by rotating the key anti-clockwise through 90° and remove the key.



If the Shield Plate (1) is tight against the face of the wheel then no further adjustment is required. If, however, there is a gap between the back face of the Shield Plate (1) and the face of the wheel then Spacer Rings (5) must be used.

Try to gauge the amount of gap and add the necessary amount of Spacer Rings (5) between the Shield Plate (1) and the Lock Unit (3) as shown in Fig.A.

If you add too many Spacer Rings (5) it will not be possible to fully engage the Lock Unit into the Receiver nut and rotate the key to lock it. If this happens then simply remove one Spacer Ring at a time until you achieve a secure fitment.

Once satisfied with the fit between the Shield Plate (1) and the face of the wheel, the Spacer Rings (5) can be retained in place by securing the Lock Unit (3) to the Shield Plate (1) by tightening the Lock Unit Hex Screw (6) using the supplied 3mm Hex Key (7).

STEP 4

The Nemesis Pro is now ready for use. Please check the Receiver nut torque setting after the first 100 miles (approx) and at regular intervals thereafter.



MAINTENANCE

Fit protective Lock Cap (9) over shield plate (1) to help prevent ingress of dirt or water.

Grease the lock face and ball bearings before first use, with a light oil such as 3-IN-ONE or equivalent.

Thereafter spray any moving parts of the lock body with a light oil such as 3-IN-ONE or equivalent every eight weeks.

Please store your keys in a safe place and remember to register your product.

Registration is quick and simple, go to www.purplelineusa.com

Please register within 14 days of purchase. Please retain your original purchase receipt.

DISCLAIMER

If used properly, your FullStop® product will be an effective deterrent. However, nothing can stop the efforts of the most determined thief, and to this end no liability is accepted for any loss and/or damage caused by any illegal activity including theft or vandalism. Liability also not accepted for any loss and/or damage arising from misuse, unauthorised repair or alteration and failure to follow the user guide directions. No form of consequential loss what so ever will be accepted.

WWW.PURPLELINEUSA.COM | 925.215.7315

701 WILLOW PASS RD. STE 8, PITTSBURG, CA 94565

